



# SIG Cavity Wall Insulation 40 Installation Manual

[www.sigdistribution.co.uk](http://www.sigdistribution.co.uk)

**SIG** RETROFIT

# SIG CWI 40

SIG CWI 40 insulation is a blown glass mineral wool insulation

- Designed with a specialist installation method for external masonry cavity walls
- Non-combustible
- Thermal performance of 0.040W/mK
- Suitable for new-build or retrofit

## SIG CWI 40 Application

Can be used in external masonry walls up to and including 12m in height, with nominal cavity widths not less than 50mm, in new and existing domestic and non-domestic buildings.

The product may also be used in buildings over 12m in height where a height restriction waiver has been issued by SIG Retrofit.



TECHNICIAN TRAINING, ASSESSMENT, APPROVAL AND INSPECTIONS	4
CAVITY WALL INSULATION TRAINING PROGRAMME	5
TYPICAL EQUIPMENT CHECK LIST	6
CUSTOMER CARE	7
PRE AND POST INSTALLATION CHECKS	8
DRILLING OPERATION	9
DRILLING PATTERN	10
INJECTION MACHINERY	13
QUALITY CHECKS	14
THE FILLING OPERATION	15
INSTALLED DENSITY CHECKS	17
MAKING GOOD	18
TECHNICIAN SAFETY CHECK SHEET - FLUES, CHIMNEYS AND COMBUSTION VENTILATORS	19
NEW BUILD INSTALLATIONS	20
NEW BUILD SURVEY	21
NOTES	23



# Technician Training, Assessment, Approval and Inspections

## THE FOLLOWING IS A GUIDE TO TRAINING REQUIREMENTS PRIOR TO APPROVAL OF THE INSTALLATION TECHNICIAN.

### EXISTING APPROVED INSTALLING COMPANY

- A training programme to be carried out by the installing company to include, company induction, health & safety, customer care and on-site training with qualified technician(s) covering all aspects of installation procedures
- Attend an approved training centre for training course on flues, chimneys and combustion air ventilators (NOTE: Not to be completed online)
- Attend a SIG Retrofit classroom training session as required. Continuation of on-site training with qualified technician(s) overseen by SIG Retrofit (Technical System Support Manager)
- Technician assessment and approval. An assessment will be carried out by SIG Retrofit (Technical System Support Manager) at the end of the training period to ascertain if the trainee technician is competent to become an approved technician. When approved the technician will be supplied with an ID card confirming approval
- Technician ID card should be kept on person at all times for on-site inspection

### NEW APPROVED INSTALLING COMPANY

- Technician training for a new approved installing company will be carried out under the guidance and supervision of SIG Retrofit as the System Certificate Holder
- Attend an approved training centre for training course on flues, chimneys and combustion air ventilators (NOTE: Not to be completed online)
- Installing company training should include, introduction into the company, general health & safety and customer care
- Attend a SIG Retrofit classroom training session which covers all basic installation procedures when installing cavity wall insulation
- Technician assessment and approval. An assessment will be carried out by SIG Retrofit (Technical System Support Manager) at the end of the training period to ascertain if the trainee technician is competent to become an approved technician. When approved the technician will be supplied with an ID card confirming approval
- Technician ID card should be kept on person at all times for on-site inspection

### ON-SITE INSPECTIONS

- Following approval each Technician will be inspected on-site a minimum of four times in each year evenly spread throughout the year
- A technician's card will be withdrawn where it is shown that the technician no longer has the capability, intention or competence to undertake the installation in a correct manner

**NOTE:** Prior to assessment the following would be required:

- a) Copy of valid ACoP's (Approved Code of Practice) certificate for flues, chimneys and combustion air ventilators
- b) Documentation from installing company listing training development
- c) Recent passport sized photograph

# SIG Cavity Wall Insulation 40 Training Programme

Once all boxes are ticked, please contact your SIG Technical System Support Manager for assessment.

Company: \_\_\_\_\_

Approved installer: \_\_\_\_\_

Name of technician: \_\_\_\_\_

Starting date: \_\_\_\_\_

Person responsible for training: \_\_\_\_\_

- |   |   |
|---|---|
| <input type="checkbox"/> External ACoPs accreditation validated | <input type="checkbox"/> Fitting cavity barriers/brushes          |
| <input type="checkbox"/> Induction course (office)              | <input type="checkbox"/> Sleeving and reinstatement of air bricks |
| <input type="checkbox"/> On-site training                       | <input type="checkbox"/> Operation of blowing machine             |
| <input type="checkbox"/> Health and safety                      | <input type="checkbox"/> On-site quality control (test box etc.)  |
| <input type="checkbox"/> Customer care                          | <input type="checkbox"/> Filling operation                        |
| <input type="checkbox"/> Pre-installation checks                | <input type="checkbox"/> Making good                              |
| <input type="checkbox"/> Drilling patterns                      | <input type="checkbox"/> Post-installation checks                 |
| <input type="checkbox"/> Drilling operation                     | <input type="checkbox"/> Flues and combustion air                 |

At the end of the training programme, SIG Retrofit (Technical System Support Manager) will test the technician to ensure that he or she has acquired a good basic knowledge of installing Cavity Wall Insulation.

## Declaration

This is to confirm that \_\_\_\_\_ has completed the above training  
on the \_\_\_\_\_ System(s)

Agrément Certificate Number \_\_\_\_\_

Technical System Support Manager signature: \_\_\_\_\_

Technician's signature: \_\_\_\_\_

Date: \_\_\_\_\_

Representation of SIG Retrofit Training Programme available on request.

# Typical Equipment Check List

- ✓ Appropriate blowing machine (see page 13)
- ✓ Lorry or trailer
- ✓ SIG CWI 40 Installation kit, consisting of:
  - ✓ 3 x 15m length hose @ 51mm diameter
  - ✓ 2 x 51mm hose connectors
  - ✓ 6 x 51mm hose clips
  - ✓ 1 x 22mm or 25mm injection nozzle (22mm for retro-fit installations, 25mm for new build installations)
  - ✓ 1 x 500mm x 500mm x 100mm test box (either a steel or a wooden box)
- ✓ 0 - 2 kg spring balance scales
- ✓ Additional access equipment as required in accordance with HSE guidance
- ✓ Inspection lamps
- ✓ Drilling machines (110v heavy duty with safety clutch)
- ✓ Hand tools, including chisel/hammer etc.
- ✓ Yard brush, shovel, dustpan & brush, rubbish bags
- ✓ Making good equipment: trowel, jointing bar/trowel, mortar hawk, mortar or sand & cement, range of colour pigments, rendering finishes, mixing bowl/bucket
- ✓ Personal protective equipment and access safety kit
- ✓ Tool kit: spanners, screwdrivers, hacksaw, hammer, pliers

# Customer Care

**THE FOLLOWING POINTS MAY SEEM OBVIOUS BUT IT IS IMPORTANT TO REMEMBER THAT THIS COULD BE THE CUSTOMER'S FIRST EXPERIENCE OF CWI.**

## **PRE-INSTALLATION**

- 1** Confirm that you are at the correct address and identify yourself to the customer, addressing them by name and presenting your credentials
- 2** Request permission to park on the customer's property and outline the access required and the procedure to be carried out. Ensure you include information on the use of any ladders, planks, scaffolding or towers to be used
- 3** If it is not a detached property confirm that all the neighbours are aware of the work being carried out
- 4** Ensure any vehicles or washing that may be damaged are removed and windows are closed before commencing work
- 5** Identify and communicate any issues including defects to the customer and report on work card before commencing work

## **DURING INSTALLATION**

- 1** Request permission to use the customer's toilet facilities if required
- 2** Avoid criticism of competitor companies
- 3** Do not respond negatively to any complaints simply follow procedure by recording, referring to your company and assuring the customer that it will be dealt with in an efficient and timely manner
- 4** Do not argue with the customer under any circumstance
- 5** Ensure any damage caused however small is reported both to the customer and to your company and the customer is advised it will be dealt with appropriately

## **POST-INSTALLATION**

- 1** Remove all rubbish and thoroughly clean up any mess once work is complete
- 2** Ask the customer to examine and inspect the work carried out and sign any appropriate compliance and satisfaction paperwork

# Pre and Post Installation Checks

## **PRE - INSTALLATION CHECKS**

Must be carried out by the installation crew to ensure that, the property is suitable and to familiarise themselves as to the property details, confirm suitability, carry out safety checks on all heating appliances and that, all ventilators are of the required standard and functioning correctly.



## **POST - INSTALLATION CHECKS**

Must be carried out to ensure that the installation has been completed, and that no damage has occurred to the property.

All heating appliances /ventilators must be checked for safe operation and results documented and make sure that the customer is satisfied before leaving site.



# Drilling Operation

Every care should be taken to minimise the amount of debris that falls into the cavity.

When drilling holes through the outer leaf, make sure they do not slope inwards towards the cavity.

When drilling facing brickwork, make sure the holes are drilled at the base of the mortar joint.

All drilling must be completed on one elevation and at least 2m of the adjacent elevations before injection commences on that elevation.

Care should be taken when drilling next to building features. It is advisable to drill at least two courses below such features.

With a new build property, you can fill via the inner leaf, before the walls are plastered. However all holes must be drilled in the mortar joints and not through the blocks or bricks.

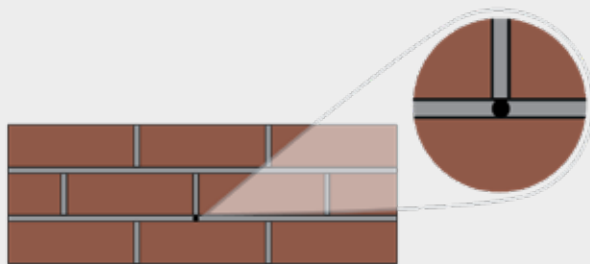

ALWAYS DRILL AT BASE OF MORTAR JOINT

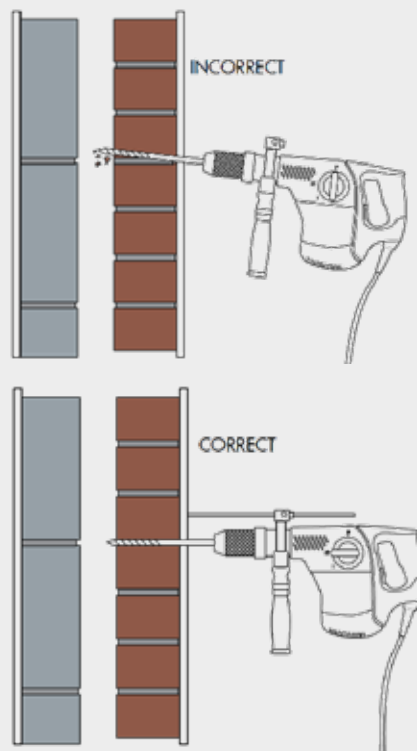

# Drilling Pattern

## HOLE DIAMETERS

- SIG CWI 40: 22mm or 26mm

Subject to the constraints given below, the distance between successive injection holes should be a maximum of 1.35m.

Wherever possible, a diamond pattern should be used so that an injection hole in one row is midway between holes in the rows above and below.

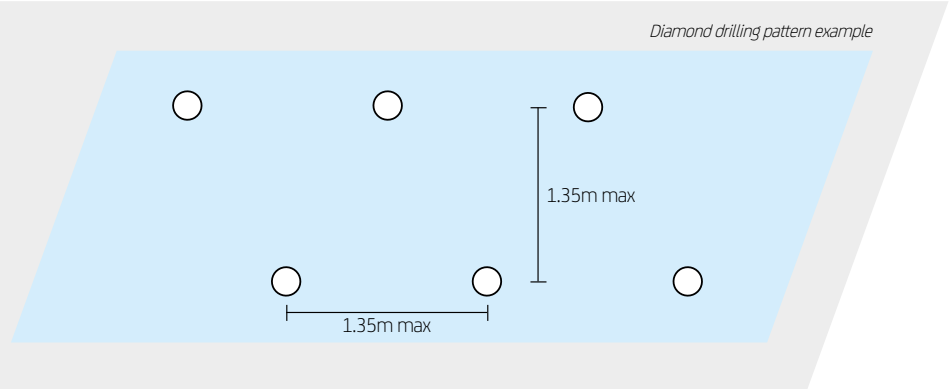

At the tops of walls and under gables, the topmost injection holes should not be more than 0.35m below the upper edge of the cavity to be filled. Additionally, under horizontal boundaries, for example under eaves, windows or lintels, the centres between the topmost injection holes should not exceed 1.0m.

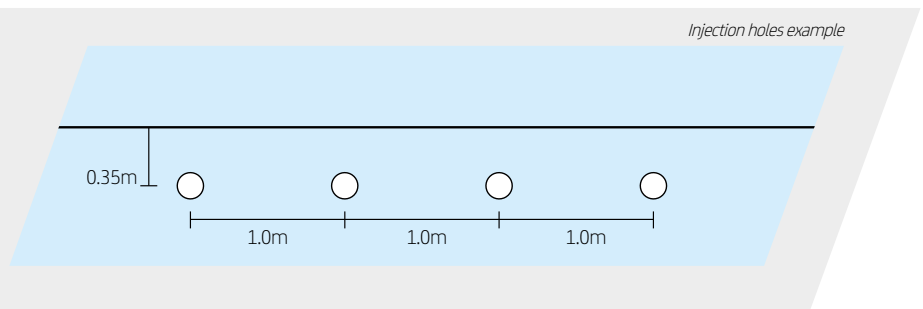

With sloping boundaries, for example under the eaves of a gable end, the centres between the successive injection holes should be between 1.0m and 1.35m depending on the slope of the boundary. The nearer the boundary is to the horizontal, the closer together the holes should be.

The lowest blowing holes should not be more than 0.8m above the horizontal Damp Proof Course (DPC).

Extra injection holes will be required to ensure completeness of fill around building features. Where lintels project beyond a vertical cavity closure the 0.35m rule shall apply.

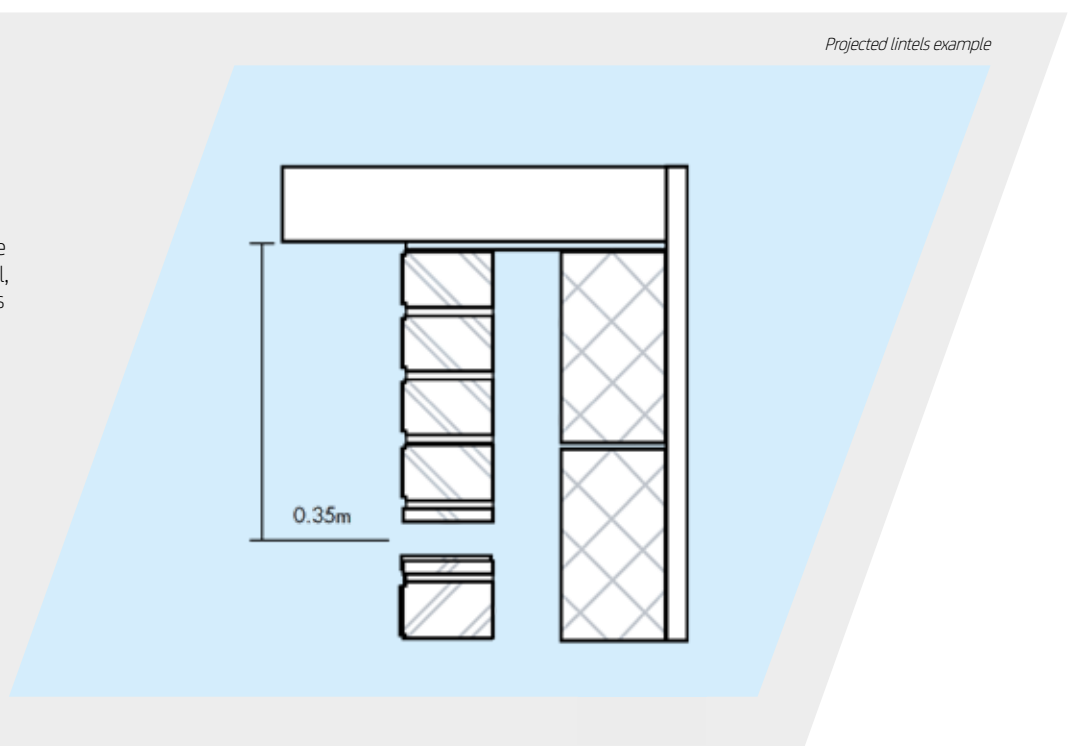

# Drilling Pattern

## TYPICAL SIG CWI 40 DRILLING PATTERN - FRONTAGE

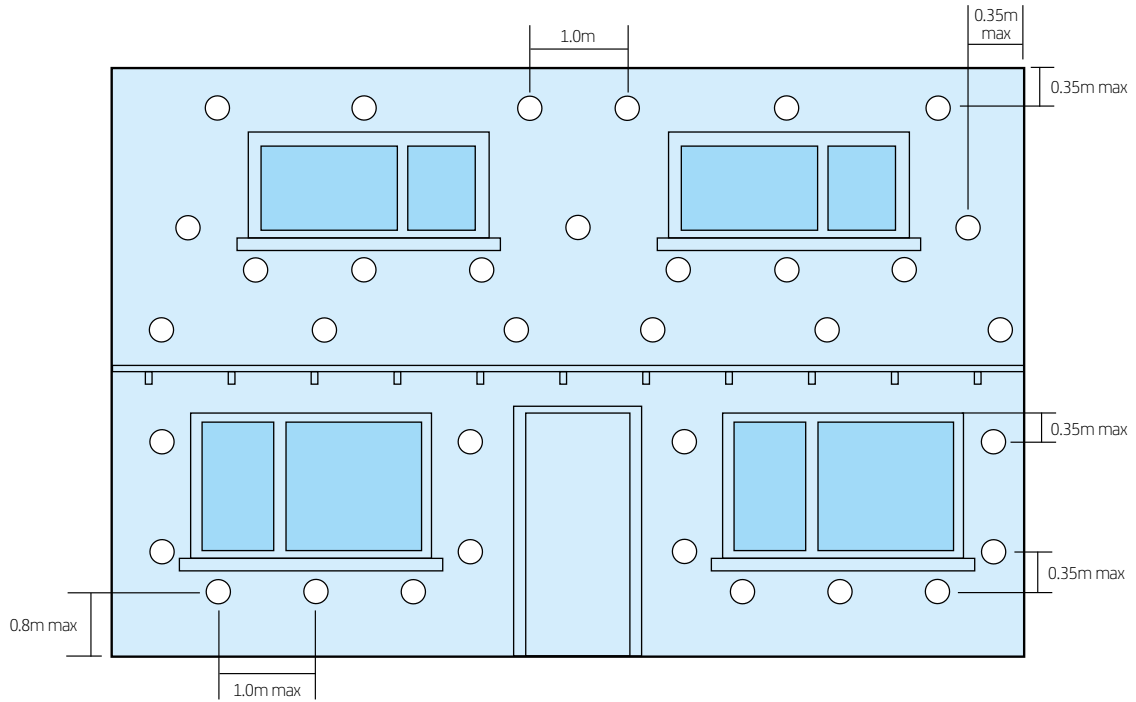

## TYPICAL SIG CWI 40 DRILLING PATTERN - PLAIN GABLE END

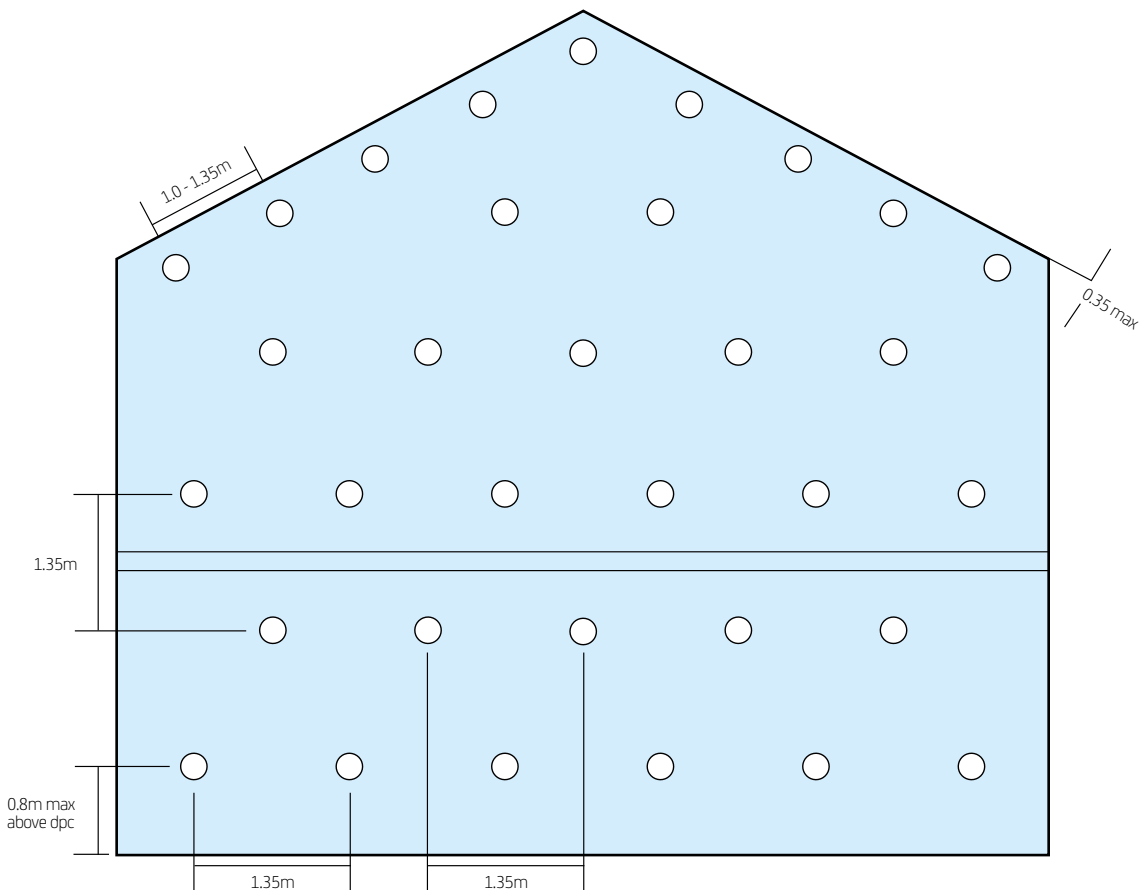

# Drilling Pattern

## TYPICAL DETACHED HOUSE ELEVATIONS



# Injection Machinery

SIG CWI 40 insulation must be installed using an appropriate blowing machine.

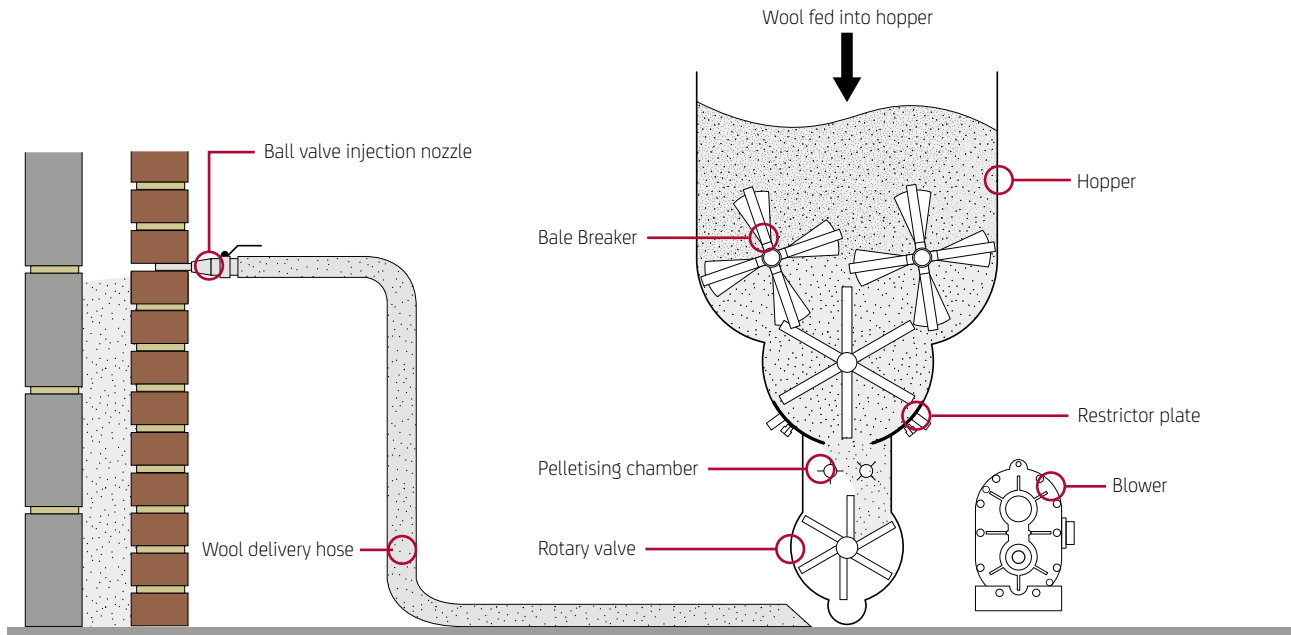

- The BALE BREAKER opens up the compressed bale of blowing wool
- In the PELLETISING CHAMBER, the bale is agitated
- The adjustable RESTRICTOR PLATE at the base of the pelletising chamber controls the wool residence time in the chamber, which in turn controls the pellet characteristics to achieve the required installed density
- As the processed insulation passes through the ROTARY VALVE it enters the airstream generated by the BLOWER and passes into the blowing hose and through the BALL VALVE INJECTION NOZZLE for delivery in to the cavity being insulated
- A pressure switch is connected to the machine control circuits, when actuated it causes the drive clutches to disengage thus stopping the blower and wool feed once the cavity wall area is filled to the required density
- An air adjustment control is fitted to all blowing machines and is used for control of the installed density

# Quality Checks

The Blowing Wool to be used has been subjected to strict quality control procedures during manufacture and it is necessary to check that it has been kept clean and dry.

## PRESSURE SWITCH

A daily calibration check should be carried out to ensure that the blowing machine pressure switch is operating correctly.

Start the engine and insert the nozzle into a breathable bag. Start blowing wool into the bag whilst watching the blowing pressure gauge. Block off the nozzle gently inside the bag. Blowing should cease when the gauge registers 260 - 280 mbar.

If necessary adjust the switch. To adjust, using a small screwdriver turn the screw in to increase the pressure and out to lower the pressure.

## NOTE

Additionally, the air adjustment control fitted to the blowing machines should be used for control of the density.

- To increase density - reduce air being dumped.
- To reduce density - increase air being dumped.

Recommended blowing machine operating pressure:

- Air only: 120-160 mbar
- Air & wool : 180-220 mbar

## WOOL DENSITY CHECK

Fill test box with wool and note time taken (typically between 20 - 45 seconds).

Check visually that box has been completely filled.

Empty contents of box into a bag and weigh - the optimum weight for SIG CWI 40 is as follows:

Product	Weight (kg)	Installed density (kg/m <sup>3</sup> )
SIG CWI 40	0.9 (±0.1)	18

If the weight is below the optimum weight, close the restrictor plate one quarter turn.

If the weight is greater than the optimum weight, open the restrictor plate one quarter turn.

Then blow into a bag to empty the pipe and re-fill the test box. Re-check weight and repeat if necessary.



## The Filling Operation

Filling should proceed from the bottom to the top of walls and from the most to the least restricted sections. Filling from the bottom ensures a uniform fill.

The blowing machine is simple to operate, 1 - 2 bales of wool can be emptied into the hopper at once. It is not recommended to allow the hopper to get less than half full. The feed rate is automatically controlled and the only necessary adjustment will be to the restrictor plate, air adjustment control or engine revs in order to obtain the correct density fill.

Insulant should be introduced into each injection hole in turn. Starting at one end of the elevation, at the bottom of the wall, work across from side to side.

The tip of the nozzle is inserted into the pre-drilled hole. Nozzle rotation is not required.

Once the blowing machine has started, the insulant will continue to flow at a steady rate until a signal from the pressure switch de-energises the clutches, indicating that the part of the cavity adjacent to the injection hole is now filled to within the nominal density required.

When filling of the hole is complete, shut off the ball valve before removing the nozzle.

Once the nozzle has been moved into the next injection hole, re-open the ball valve so that injection of insulant can continue by activating the start switch.



# The Filling Operation

## TYPICAL SIG CWI 40 FILLING PATTERN - FRONTAGE

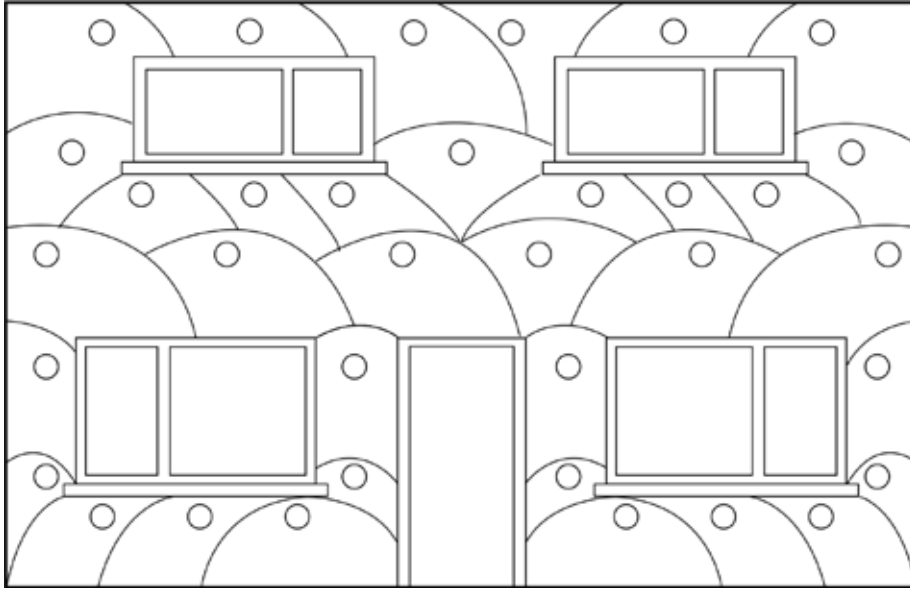

## TYPICAL SIG CWI 40 FILLING PATTERN - PLAIN GABLE END

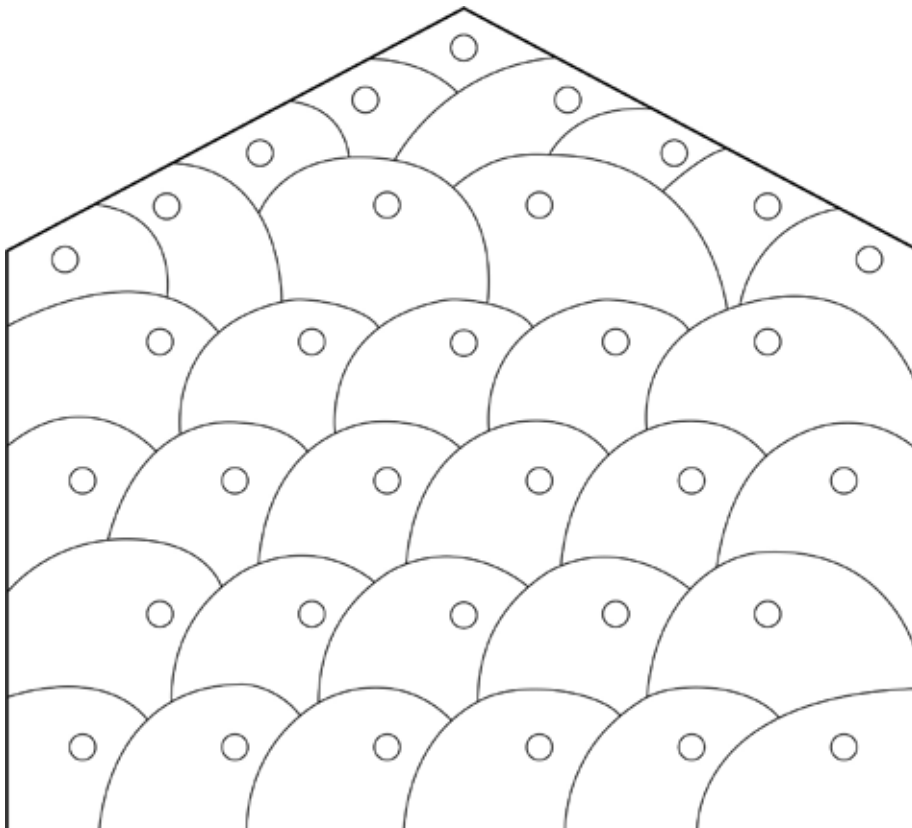



# Installed Density Checks

## INSTALLED DENSITY CHECKS

To check that the correct fill has been obtained, the number of bales used on site and average cavity width should be recorded on the work card and an average installed density calculated.

### FOR EXAMPLE:

#### SIG CWI 40

Gross Area of Walls	110m <sup>2</sup>		
Less Openings	27m <sup>2</sup>		
Net Area	83m <sup>2</sup>		
Average Cavity Width	65mm = 0.065		
Volume of Cavity	83m <sup>2</sup> x 0.065	=	5.4m <sup>3</sup>
No. of SIG CWI 40 Bags Used	5.5 x 17.6kg	=	96.8kg
			-----
			5.4m <sup>3</sup>
			= 18kg/m <sup>3</sup>

Cavity widths can vary considerably within one building. Therefore at least ten cavity width measurements should be made at various heights in the building.

(Cavity widths can tend to vary the greater distance from ground level).

### NOTE:

For an average density of 18kg/m<sup>3</sup> the following coverage can be obtained.

Cavity Width - mm	50	55	60	65	70	75	80	85	90	95	100
Coverage - m2/bale	19.53	17.80	16.30	15.00	14.00	13.00	12.20	10.90	10.80	10.30	9.80

# Making Good

The importance of making good after the installation cannot be over-emphasised. Leaving the property in the same condition that you found it in is the best possible recommendation and source of new leads.

## MAKING GOOD HOLES

A mortar mix should be made up before the installation begins. That way the preceding holes can be made good while the next hole is filling. It also allows adjustments to be made to the colour match when required. Make sure that the customer understands that although every effort is made to match the existing finish particularly to painted areas it may be difficult due to weathering etc.

## BRICK FACED PROPERTIES

Wet an area of wall to give you a better match indication. Choose the correct type and colour of sand for the local area. Different parts of the building may require different colours/mixes to match the existing mortar (mortar dyes may help to achieve the match). In some cases it may be necessary to touch-up the corners of the brick with mortar dyes.

## RENDERED/TYROLENE-FACED/PEBBLE DASH AND SPA CHIPPING FINISHES WALLS.

Special care must be taken with rendered walls, the colour and texture of the facing type being chip/pebble/spa-chippings etc, these should be copied as closely as possible. It may be possible to re-use spa chippings from drilling debris. Remember that your mortar mix may need to be slightly wetter, in order to retain the chippings.



# Technician's Safety Check Sheet

## Flues, Chimneys & Combustion Air Ventilators

Date: \_\_\_\_\_

Job Reference Number: \_\_\_\_\_

Customer Name: \_\_\_\_\_

Property Address: \_\_\_\_\_

\_\_\_\_\_

This Check sheet specifies the minimum checks, and actions that must be carried out during installation of CWI to buildings containing fuel-burning appliances. It must be read in association with "Technicians guide to best practice - Flues, chimneys and combustion air ventilators."

### Survey, Identify & Record

Fuel type(s) Gas \_\_\_\_\_ Oil \_\_\_\_\_ Coal \_\_\_\_\_ Wood \_\_\_\_\_ Bio-mass \_\_\_\_\_

Appliance type(s) Boiler \_\_\_\_\_ Gas Fire \_\_\_\_\_ Open Fire \_\_\_\_\_ Balance Flue \_\_\_\_\_

Flue / chimney location(s) Internal Wall \_\_\_\_\_ External Wall \_\_\_\_\_ Front \_\_\_\_\_ Side \_\_\_\_\_ Rear \_\_\_\_\_

Location of combustion air ventilator(s) Front Elevation \_\_\_\_\_ Side Elevation \_\_\_\_\_ Rear Elevation \_\_\_\_\_ Roof \_\_\_\_\_

### Additional Ventilation

Additional ventilation required Y / N

Location of combustion appliance \_\_\_\_\_

Type of combustion appliance \_\_\_\_\_

kW rating of appliance requiring additional ventilation \_\_\_\_\_

mm<sup>2</sup> of free air installed \_\_\_\_\_

Comments
----------

### Pre-Installation Checks

Appliances identified, flue / chimney routes, internal & external Y / N

Appliance run\*\* Y / N

View & note flame colour\*\* Y / N

Combustion gases check externally\*\* Y / N

Appliance checked (smoke test / spillage test)\*\* Y / N

Smoke / spillage test satisfactory\*\* Y / N

Combustion air supply adequate Y / N

Comments
----------

### Installation - Visual Check

Flue, chimney routes to avoid drilling into them Y / N

Flue, chimney routes to avoid ingress of material Y / N

Combustion air ventilator(s) unobstructed Y / N

Comments
----------

### Post Installation

Appliance(s) run at maximum for minimum of 5 minutes\*\* Y / N

Visual check that flame compares with pre-installation\*\* Y / N

Smoke test / spillage test satisfactory\*\* Y / N

If results were unclear, re-test after a further 10 minutes\*\* Y / N

Re-test satisfactory\*\* Y / N

\*\* Only on appliances fitted to flues & chimney on external walls Y / N

Comments
----------

If there is any doubt or any question answered N then:

1. Switch OFF appliance
2. Issue WARNING NOTICE
3. ADVISE occupants and owner
4. CALL OUT a competent body or person such as fuel supplier or maintenance contractor (e.g. Gas Safe Registered for gas).

**Important: It is the installing Company's responsibility to ensure that the Technician is trained to be able to discharge these responsibilities. Failure to carry out these safety checks could lead to the death of an occupant and prosecution of the Technician.**

Technician's Name: \_\_\_\_\_ Technician's Signature: \_\_\_\_\_

# New Build Installations

Injection must not be undertaken until all cavities are sealed. Internal installation should preferably take place before the walls are plastered.

Drilling must be in the mortar joints, to avoid spalling to the cavity face of the blocks.

The property should be inspected and defects reported prior to SIG CWI 40 being installed.



Correct

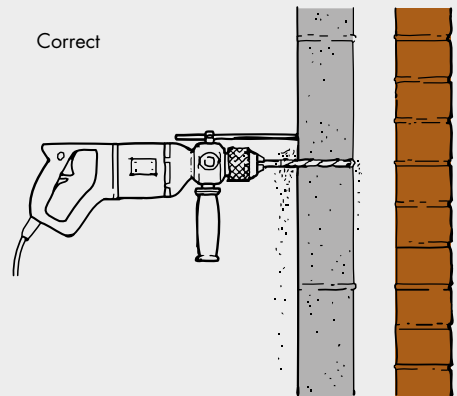

Incorrect

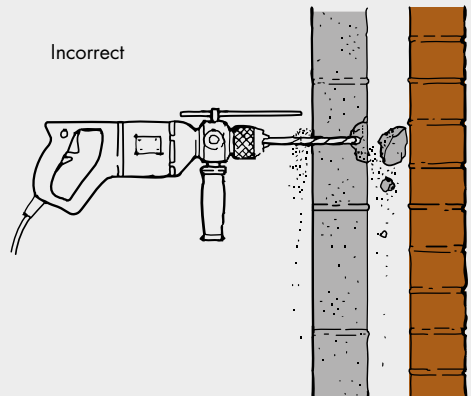

# New Build Survey and Installation Report

## FOR BUILDINGS UNDER CONSTRUCTION

### SURVEYOR/TECHNICIAN DECLARATION

#### Material used: External Wall

SIG CWI 40: Y / N  
 SIG CWI 34: Y / N  
 Supafil Frame: Y / N  
 Test box results: weight \_\_\_\_\_ kg  
 time \_\_\_\_\_ seconds

Number of bags installed: \_\_\_\_\_

Batch number: \_\_\_\_\_

Installed density: \_\_\_\_\_ kg/m<sup>3</sup>

Cavity tray's present: Y / N

Gable; Intermediate Floor: Lean to roof; DPC, Above window pier

Where: \_\_\_\_\_

\_\_\_\_\_

Do the gable apexes require insulating\*: Y / N

\*Gable apexes must be insulated if no cavity tray is present. The cavity must also be insulated if the gable apex forms part of a warm roof.

I confirm that I have inspected the building, according to Agrément Certificate Number \_\_\_\_\_ as far as can be practically determined from the visible construction, the building is suitable for installation.

Name: \_\_\_\_\_

Date: \_\_\_\_\_

Signature: \_\_\_\_\_

### SITE AGENT

Technician sign in time: \_\_\_\_\_

Technician sign out time: \_\_\_\_\_

#### Material used: External Wall

SIG CWI 40: Y / N

SIG CWI 34: Y / N

Supafil Frame: Y / N

Drill pattern inspected and compliant with system designer specification: Y / N

Cavity trays present: Y / N

Where: \_\_\_\_\_

\_\_\_\_\_

#### Material Used: Party Wall

SIG CWI Party Wall: Y / N

Cavity tray present at each floor level: Y / N

Do the gable apexes require insulating\*: Y / N

\*Gable apexes must be insulated if no cavity tray is present. The cavity must also be insulated if the gable apex forms part of a warm roof.

I acknowledge receipt of the survey form and confirm that it is factual. I also confirm that the cavity walls have been built according to the applicable regulators and standards. The cavity walls have been inspected during construction. I am not aware of defects in the construction of the cavity walls.

Name: \_\_\_\_\_

Date: \_\_\_\_\_

Signature: \_\_\_\_\_

# New Build Survey and Installation Report

## FOR BUILDINGS UNDER CONSTRUCTION

INSTALLERS JOB REFERENCE: \_\_\_\_\_

Technician 1 name: \_\_\_\_\_

Technician 2 name: \_\_\_\_\_

CSCS number: \_\_\_\_\_

CSCS number: \_\_\_\_\_

Date of installation: \_\_\_\_\_

Site address: \_\_\_\_\_

Client: \_\_\_\_\_

Client's order no: \_\_\_\_\_

House type: \_\_\_\_\_

To be installed according to Agrément Certificate No: \_\_\_\_\_

Special instructions to Surveyor and/or Technician: \_\_\_\_\_

Plot number: \_\_\_\_\_

## DETAILS OF BUILDING TO BE INSULATED

Detached/semi/terrace/other – specify: \_\_\_\_\_

Areas of external cavity wall to remain uninsulated: \_\_\_\_\_

Expected cavity wall area to be filled: \_\_\_\_\_ sq.m

Expected party wall area to be filled: \_\_\_\_\_ sq.m

Design width of cavity: \_\_\_\_\_ mm

Design width of party wall cavity: \_\_\_\_\_ mm

Internal/external filling: \_\_\_\_\_

## CONSTRUCTION

Type of brick/block: \_\_\_\_\_

Brick work complete: Y / N

Type of wall tie: \_\_\_\_\_

Weep holes to lintels: Y / N

Number of flues on outside walls: \_\_\_\_\_

Block work complete: Y / N

Mortar joints filled to external face, with weathered, bucket handle or birdsmouth jointing: Y / N

Eaves detail - sealed: Y / N

Measured width of cavity: \_\_\_\_\_ mm

Dpc free of significant mortar extrusions: Y / N

Height of building: \_\_\_\_\_ m

Cavity ties free of significant mortar build-up: Y / N

Measured area of cwi: \_\_\_\_\_ sq.m

Exposure of building satisfactory: Y / N

Roof complete: Y / N

Remedial works required before installation:

Cavity sealed at windows: Y / N

Remedial works to be undertaken by: client/installer

Air bricks sealed: Y / N

**Note:** The installation cannot be undertaken unless all answers are 'Y' (yes) or the remedial works have been completed. The operative shall document any remedial works he undertakes before, or during installation.

Meter box fitted: Y / N

## COVERAGE RATES

SIG CWI 40											
Cavity Width - mm	50	55	60	65	70	75	80	85	90	95	100
Coverage - m <sup>2</sup> /bale	19.53	17.80	16.30	15.00	14.00	13.00	12.20	10.90	10.80	10.30	9.80

SIG CWI 34					
Cavity Width - mm	90	95	100	125	150
Coverage - m <sup>2</sup> /bale	6.90	6.50	6.20	5.00	4.10

SIG CWI PARTY WALL					
Cavity Width - mm	65	75	85	95	100
Coverage - m <sup>2</sup> /bale	15.00	13.00	10.90	10.30	9.80











Find out more 0330 123 1811  
email: [retrofit@sigplc.com](mailto:retrofit@sigplc.com)  
[www.sigdistribution.co.uk](http://www.sigdistribution.co.uk)

**DISCLAIMER:** This installation manual is for technical system guidance only. Any recommendations contained within this guidance should be verified with an expert or professional for suitability and compliance with actual requirements, specifications and any applicable laws and regulations, including but not limited to the Construction (Design and Management) Regulations and the Building Safety Act. SIG does not warrant, and assumes no liability for the accuracy, completeness, applicability, suitability, or fitness for purpose for any particular installation, as a result of any information used. We encourage the system installer to carry out a thorough investigation on each of their work sites to ensure a bespoke 'safe system of work' can be developed considering each site's inherent risks, including but not limited to the following:

- Safe access to working at height
- Suitable PPE
- Asbestos removal
- COSHH and Dust control
- Hand/arm vibration (HAVS)

All rights reserved. No part of this publication may be reproduced or transmitted in any form, or by any means, electronic or mechanical including photocopy, recording or any information storage and retrieval system, without permission in writing from SIG Trading Ltd. No information contained within this publication can be used to compile any other printed or electronic directory or mailing list. Whilst every effort has been made to ensure accuracy, the publisher does not, under any circumstances, accept responsibility for errors or omissions and no representation or warranty is made in relation to the suitability of a product for a specific application. Copying of the images contained in this publication, in any form without the author's permission, is an unlawful act under the Copyright Designs and Patent Act 1988. Images used are for illustration purposes only.